

Summer Salsa Lone Star

Bonus class lesson screenshots to assemble the Rocket blocks

Summer Salsa "Rocket" Blocks



1

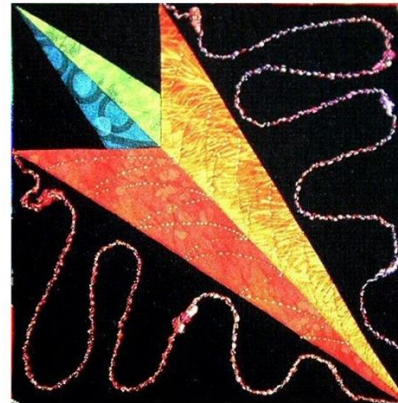

Rocket block – Summer Salsa – page 103 & 108

2

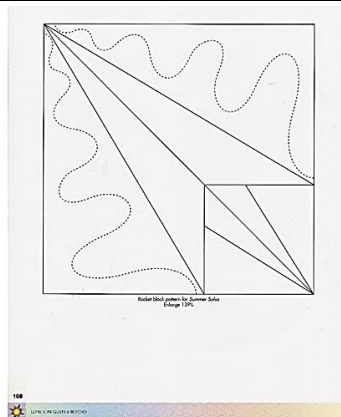

Pattern enlargement:
138 % or 143 % ??

The "Rocket" pattern appears on page 108

3

Pattern enlargement:

138 % or 143 % ??

4

Remember: Make your block
"X" measurement
plus
1/4 inch seam allowance
on all sides

5

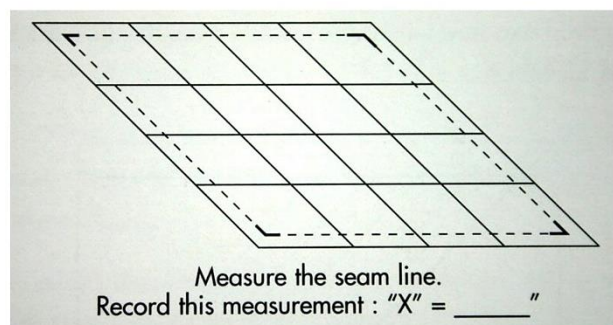

"X" measurement detail – page 58

6

Summer Salsa Lone Star

Bonus class lesson screenshots to assemble the Rocket blocks

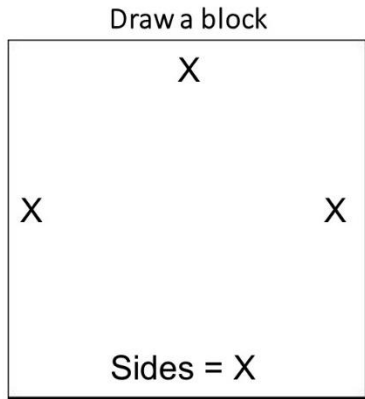

7

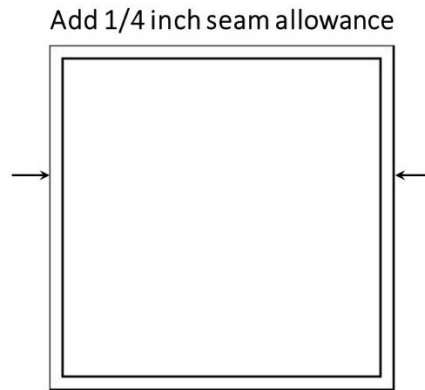

8

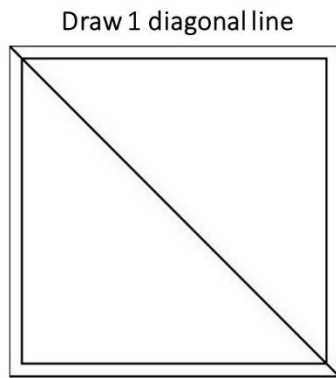

9

Position square ruler on line in one corner.
Draw a 4 inch square.

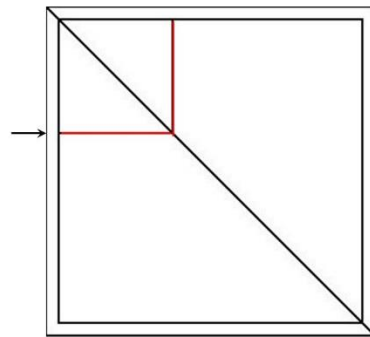

10

Draw a line between square and opposite corner.

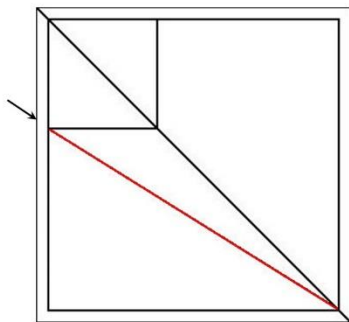

11

Draw 2nd line between square and opposite corner.

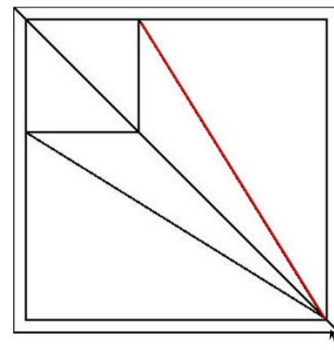

12

Summer Salsa Lone Star

Bonus class lesson screenshots to assemble the Rocket blocks

Measure 1-1/2" from center line.
Draw a line to the upper left corner.

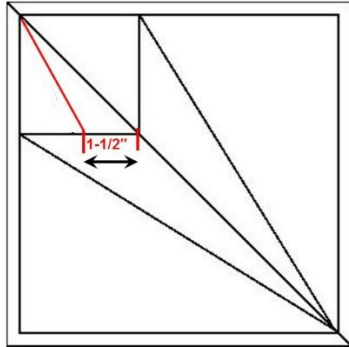

13

Measure 1-1/2" from center line.
Draw 2nd line to the corner.

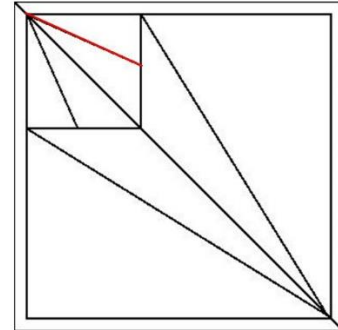

14

Constructing Rocket Blocks

Combination of
Template &
Foundation piecing techniques

Stack 8 pieces of freezer paper *shiny side up* beneath master drawing, align edges.

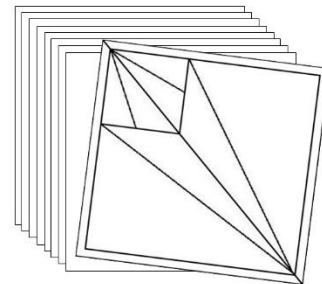

15

16

Staple (or sew) all layers together in the 4 corners, at least 3/4" away from the lines

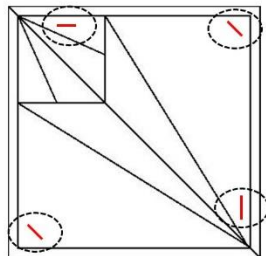

17

Remove the thread from the sewing machine.

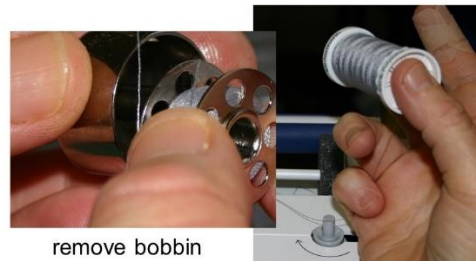

remove bobbin

remove upper spool

18

Summer Salsa Lone Star

Bonus class lesson screenshots to assemble the Rocket blocks

Stitch on ALL the lines:

- perforating the stack of papers
- duplicating the pattern through all layers

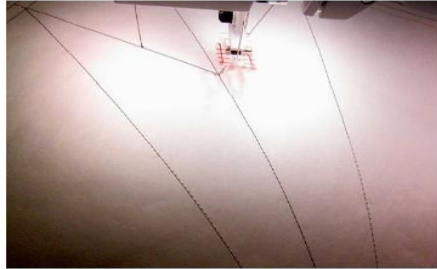

19

Remove staples and separate all layers.

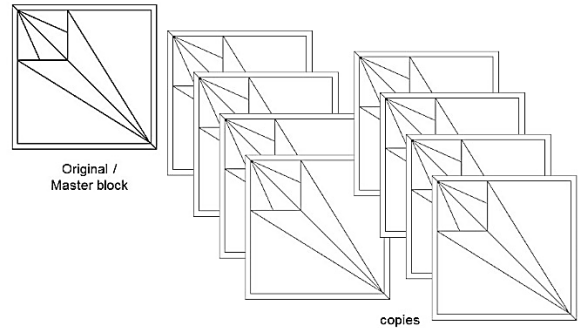

20

Color-code the master pattern.
Colors will be in mirror image on the back, and correct placement on the finished block.

Paste fabric swatches onto the dull side of the pattern with glue stick or Roxanne's glue-baste

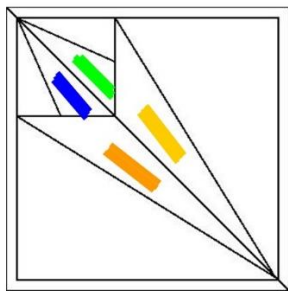

21

Color the 4 outer edges of the block with colored pencil or highlighter.

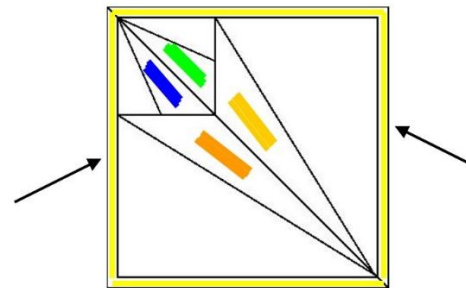

22

Add grain line arrows at block's center and edges

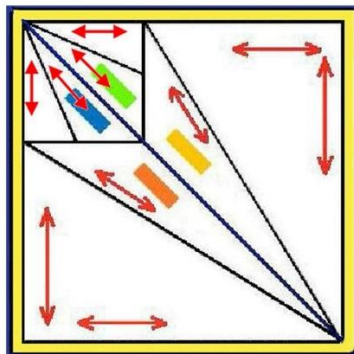

23

Cut one copy of the pattern in half diagonally

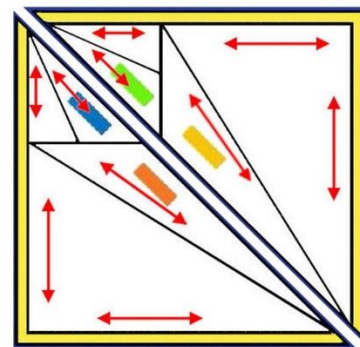

24

Summer Salsa Lone Star

Bonus class lesson screenshots to assemble the Rocket blocks

Cut one block copy into quarters

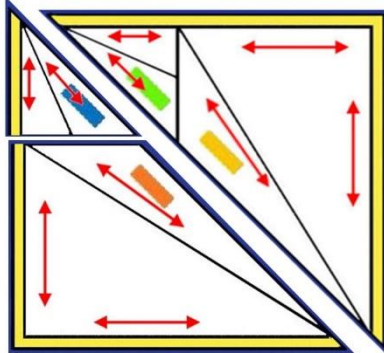

25

Set aside one half of the block

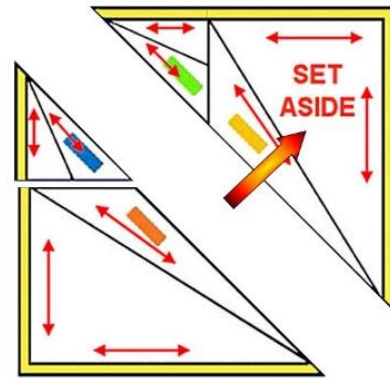

26

Working with one half of the block....

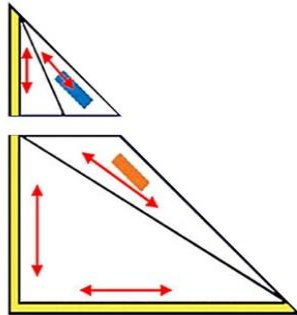

27

cut the remaining pattern shapes
apart from one half of the block

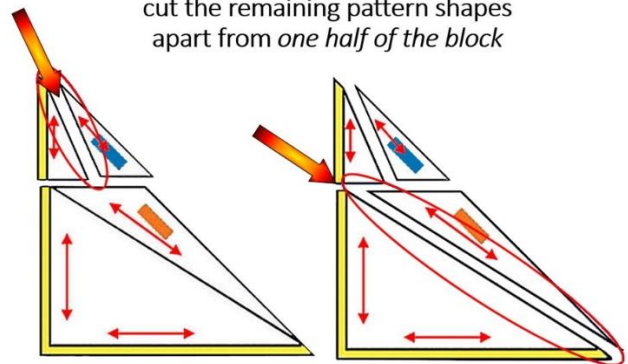

28

Measure each of the four sections, adding 3/8"
to 1/2" on all sides.

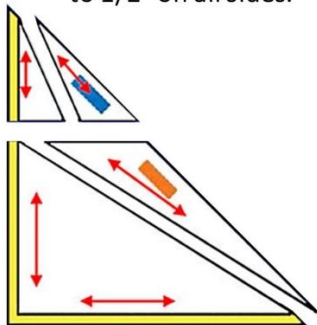

29

Remember – each piece will require a matching
mirror-image piece.

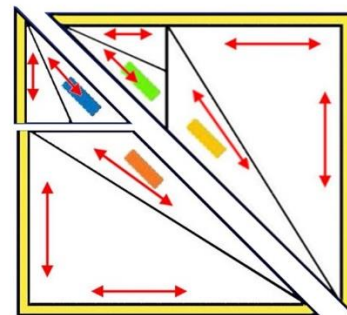

30

Summer Salsa Lone Star

Bonus class lesson screenshots to assemble the Rocket blocks

Fabrics will be layered
right sides together
for cutting.

Once pieces are cut, each *pair of cut shapes* will also be *mirror-image shapes*.

Measure and cut fabric strips for all shapes *adding 3/8" to 1/2" on all edges*

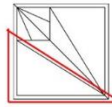

Large background shape

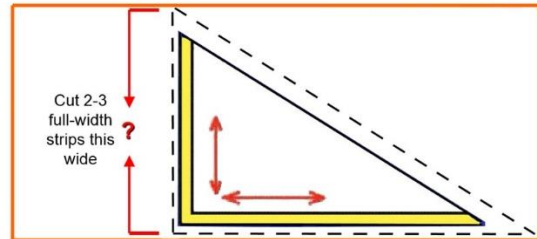

Cut 2-3 full-width strips this wide

31

32

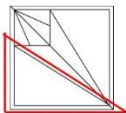

Cut 2 strips to start – if more are needed, later cut a 3rd strip.

Cut 2 strips, selvage-to-selvage x the height.

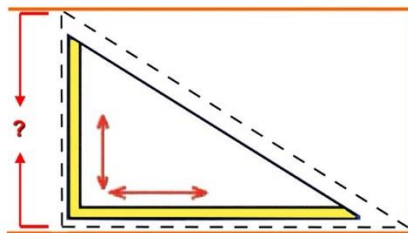

Layer the 2 strips folded, *right or wrong sides together*

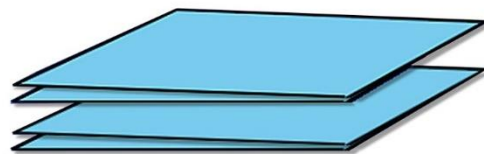

(four layers total)

33

34

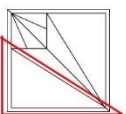

Cut through all layers, using the single template shape as the guide.

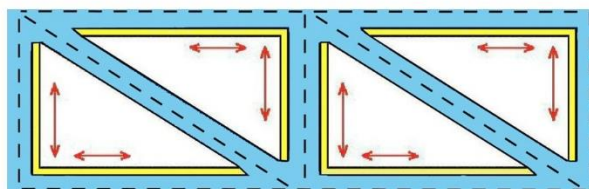

(4 layers total)

Remember: when cutting, ADD 3/8" – 1/2" around each piece. Each cut yields 2 sets of 2 corner pieces.

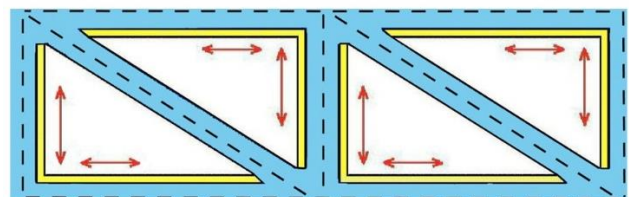

(4 layers total)

35

36

Summer Salsa Lone Star

Bonus class lesson screenshots to assemble the Rocket blocks

Number of units cut (yield) is determined by the fabric width.

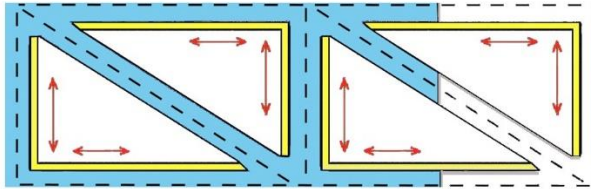

(when cutting narrow yardage)

37

For narrow strips: Cut 1 strip the correct width by measuring the smaller piece.

Unfold the remaining partial strips.

Layer two different colors right sides together. If necessary, stack a 2nd layer on the first pair, repeating the color sequence.

Position the template on the fabric.

Are you able to cut the remaining units from the fabric?

38

If necessary, cut an additional fabric strip.

Cut all mirror-image pairs.

Total: 8 mirror image pairs

39

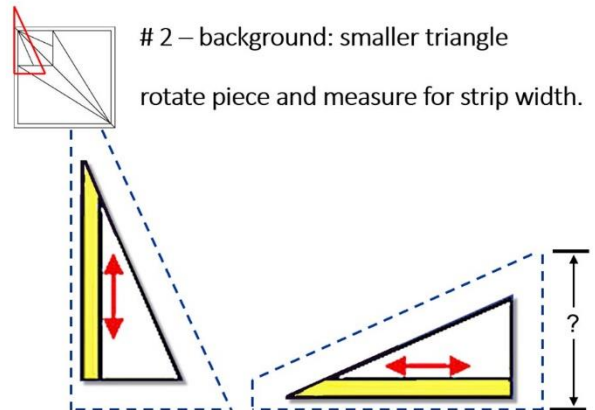

40

Begin by cutting 2 strips of each color. If more are needed, later cut a 3rd strip.

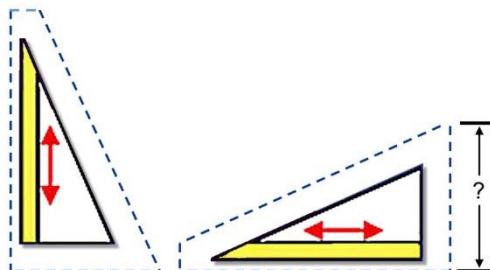

41

Layer the 2 strips folded, right or wrong sides together



(four layers total)

42

Summer Salsa Lone Star

Bonus class lesson screenshots to assemble the Rocket blocks

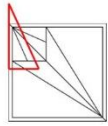

Cut through all layers, using the single template shape as the guide.

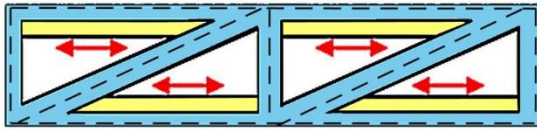

Cut 8 mirror-image pairs (2 per block)

43

Remember: when cutting, ADD 3/8" – 1/2" around each piece. Each cut yields 2 sets of 2 corner pieces.

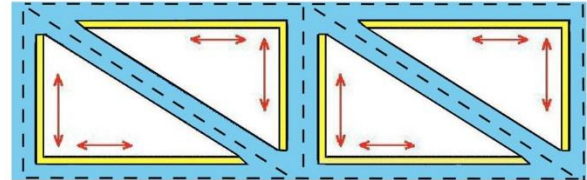

(4 layers total)

44

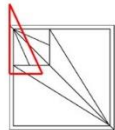

Tip: If the small template pieces are challenging to use....

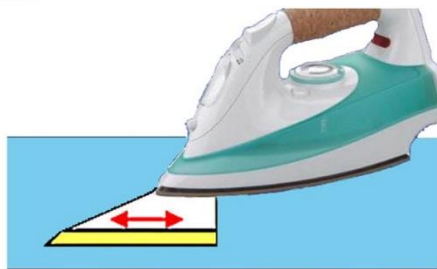

Iron it shiny side down to the fabric.

45

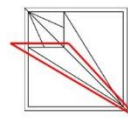

Piece #3
large "rocket blade"

Add 3/8" to 1/2" on all sides.

Cut 2 strips of EACH COLOR, selvage-to-selvage x the height.

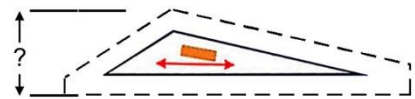

46

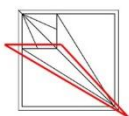

Layer one of each color fabric strip right sides together.

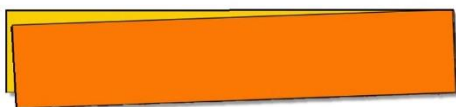

47

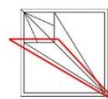

Repeat, creating two paired strips. The upper color in each pair is the same fabric as the swatch.

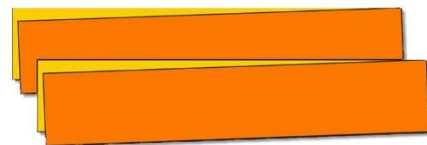

48

Summer Salsa Lone Star

Bonus class lesson screenshots to assemble the Rocket blocks

Do not change the color order of strips when stacking.

Cut 8 mirror image pairs through the stacked strips.

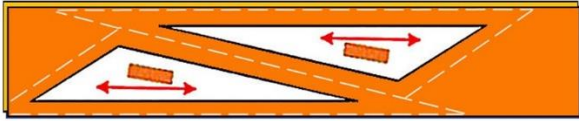

49

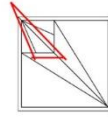

Piece # 4:
small "rocket" shape
measure for strip width

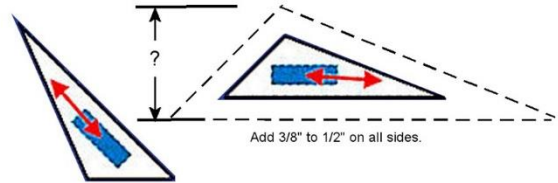

50

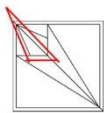

Cut 2 strips of EACH COLOR,
selvage-to-selvage X the height.

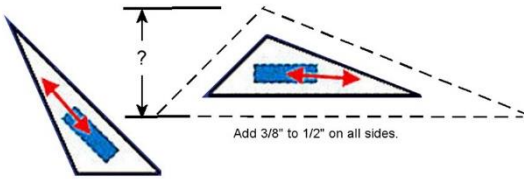

51

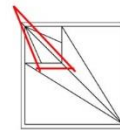

Layer one of each color fabric strip
right sides together.

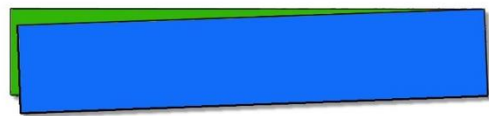

52

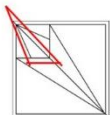

Layer one of each color fabric strip
right sides together.

Repeat, creating two paired strips. The upper
color in each pair is the same fabric as the
swatch.

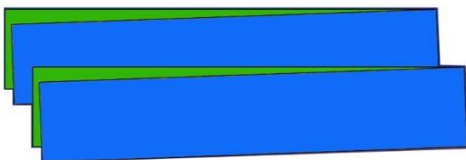

53

Do not change the color order of
strips when stacking.

Cut 8 mirror image pairs through
the stacked strips.



54

Summer Salsa Lone Star

Bonus class lesson screenshots to assemble the Rocket blocks

Lay out all of the cut pieces in the correct order, according to the master block.

Assess: are all of the pieces cut the proper direction, and do you like the fabrics together?

55

When the fabrics are positioned right side up, the block will be mirror-image to the master pattern with swatches.

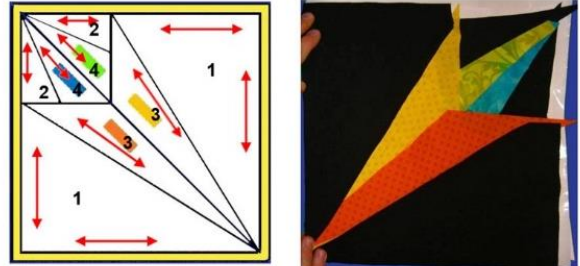

56

Sew one test block:
Sew background piece #1
+ rocket point #3.

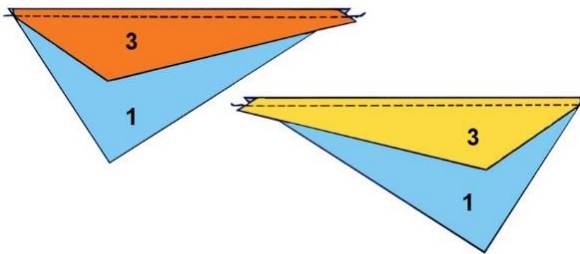

57

Press seams toward the large background piece 1

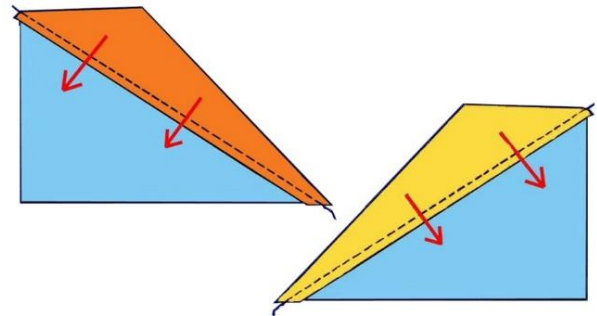

58

Sew background pieces #2
+ small "rocket" pieces #4,
in both color combinations.

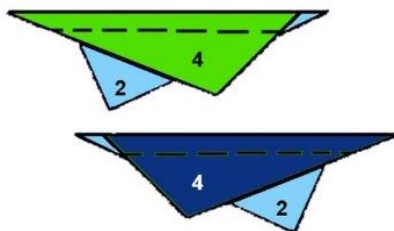

59

Press seams toward the background (piece 2)

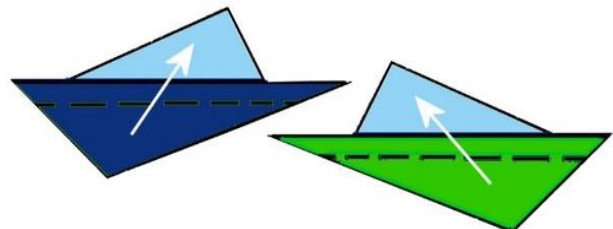

60

Summer Salsa Lone Star

Bonus class lesson screenshots to assemble the Rocket blocks

Press the paper patterns to the wrong side of each pieced section, aligning center seam.

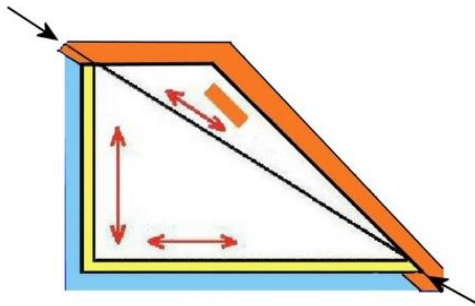

61

REMEMBER:

Allow adequate seam allowance around outside edges of paper!

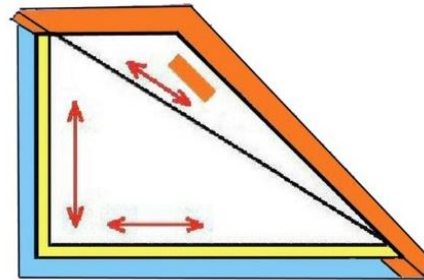

62

Trim **ONLY** the *interior edges* of the block – do not trim the highlighted 1/4" seam allowance edges

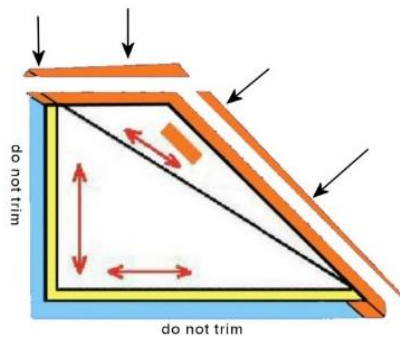

63

Press the freezer paper patterns to the wrong sides of all remaining units

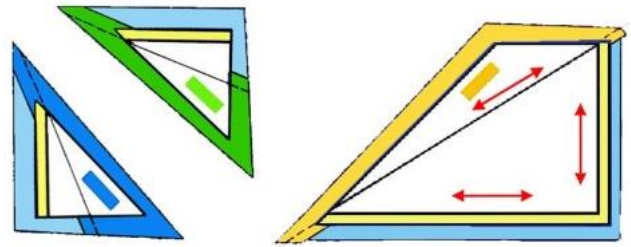

64

Trim all units in the same manner –trimming only interior seams, **NOT** the highlighted edges.

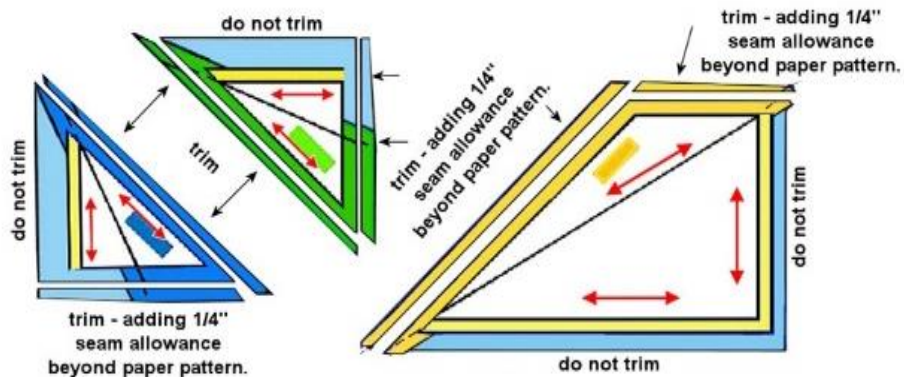

65

Summer Salsa Lone Star

Bonus class lesson screenshots to assemble the Rocket blocks

Pin to align outer points. Sew the smaller units to the larger ones, stitching at the paper's edge.

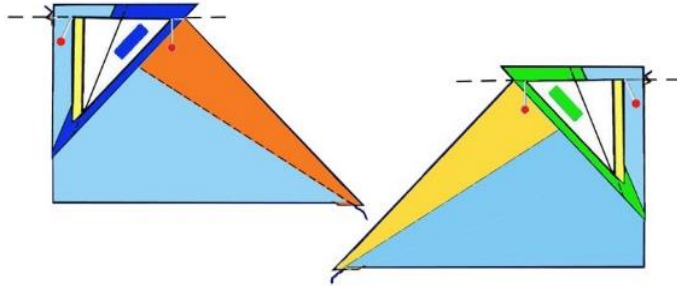

66

Press seams in alternating directions.

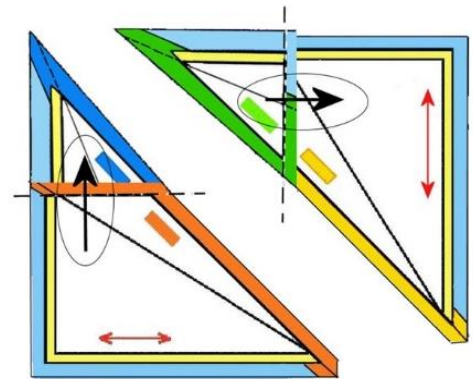

67

Pin block halves, aligning tips & opposing seams.

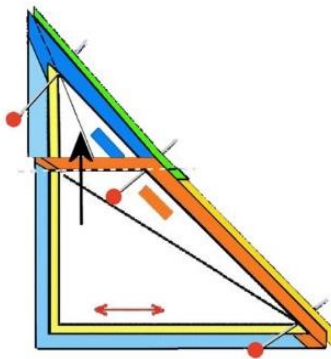

68

Sew block halves, creating full blocks.

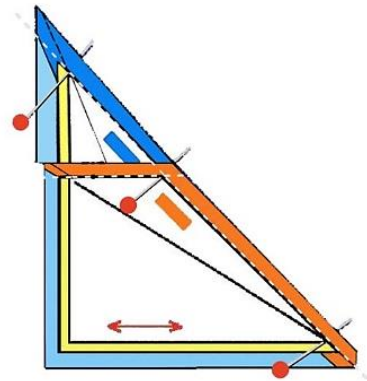

69

Press center seam open.
Trim outer edges to measure **X** plus 1/2"

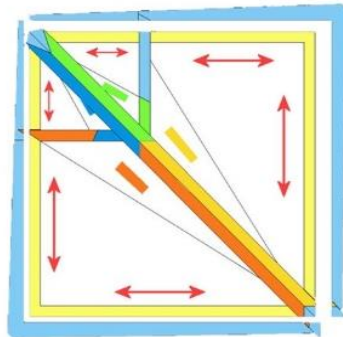

70

When trimming, use the measurements on your quilter's square ruler – NOT the edges of the freezer paper, which can shrink in the pressing process.

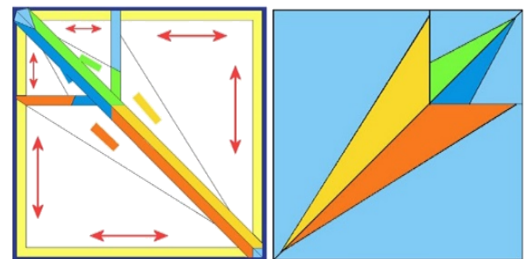

71

Summer Salsa Lone Star

Bonus class lesson screenshots to assemble the Rocket blocks

Once satisfied the 1st block is the correct size, construct a total of 8 left and 8 right sections for all units.



72

The block front will mirror the color placement of the back.

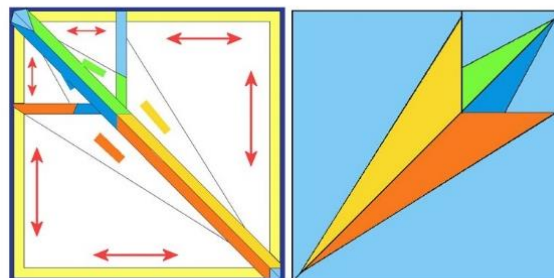

73

Do not remove paper until you assemble the star quilt top.

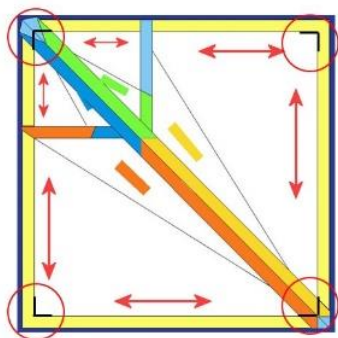

74

Mark each setting square with 1/4" seam allowances at corners.

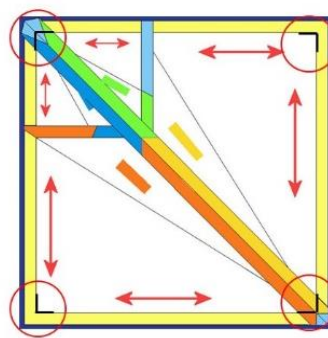

75

Please add these Rocket Block construction technique screenshot pages to your notes. They supplement the brief pattern instructions found in the Summer Salsa pattern found in *Lone Star Quilts & Beyond*.

The bonus pages are provided for you, my student. Please do not mass-produce and distribute them to others who have not taken a workshop with me. Thank you.